

AIRPAX

IELR Rail-Mount Magnetic Circuit Protectors

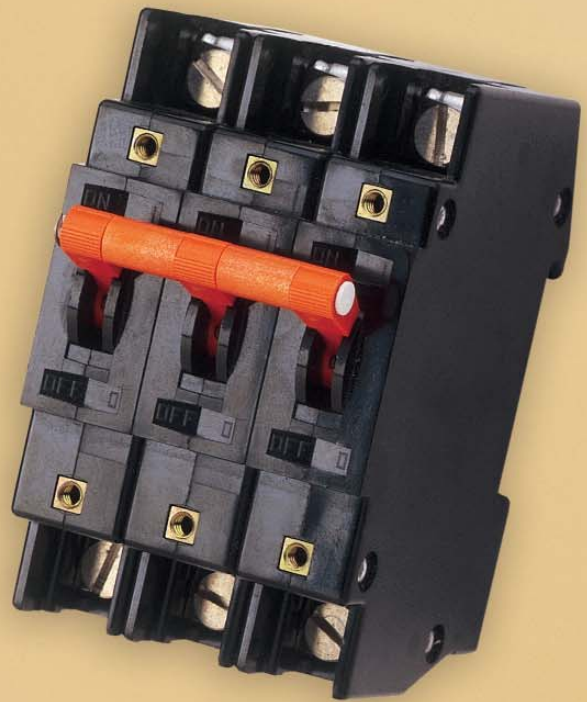



Designed specifically for the 35mm symmetrical DIN rail, Airpax IALHR, IULHR and IELHR series Rail-Mount Magnetic circuit protectors offer the advantages of quick and easy mounting or removal which results in efficient and economical wiring, while conserving space.

These circuit protectors are available in 1, 2, 3 and 4 pole models, with a choice of handle colors with on/off and international I/O markings. These protectors comply with UL and CSA standards and meet IEC and VDE spacing requirements. Typical applications include computers and peripherals, telecommunications, medical equipment, machine tools and process control instrumentation. They provide the reliable performance associated with magnetic circuit protection.

Mounting

These circuit protectors are designed to mount on standard 35mm DIN rails, such as 35x7.5 or 35x15 per DIN EN50022. Other specialty rails are available from suppliers that provide a means of mounting non DIN mount components by means of special captive jam nuts.

Magnetic Circuit Protectors	177
Configurations	178
Operating Characteristics	179
Delay Curves	180
Specifications	184
Decision Tables	184



Single Pole

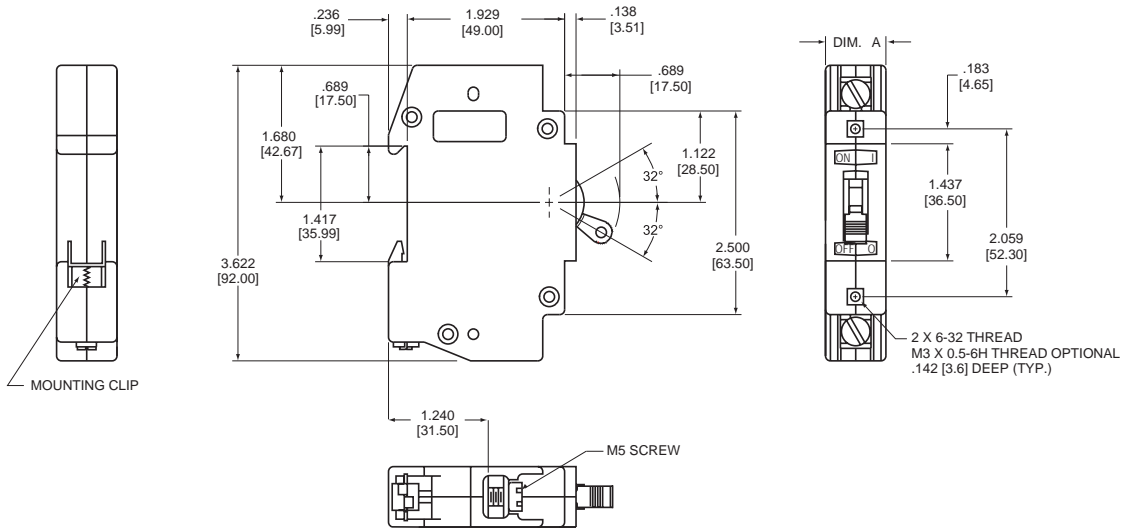

Two Pole

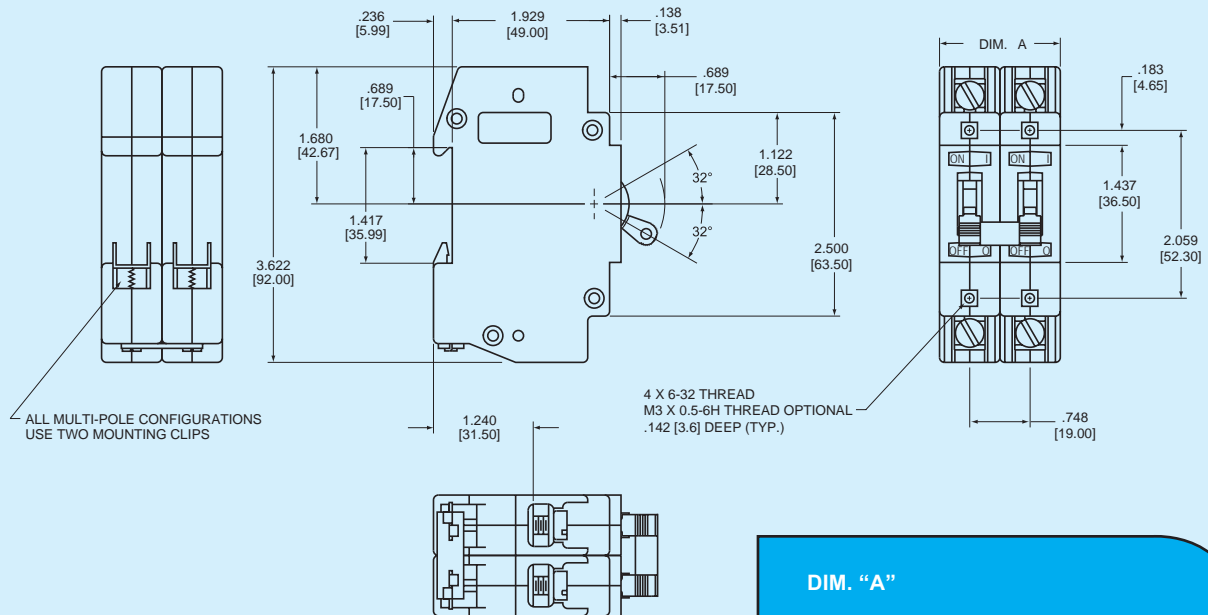

ALL MULTI-POLE CONFIGURATIONS USE TWO MOUNTING CLIPS

DIM. "A"	
1 pole	.750 ± .02 (19.05 ± .5)
2 pole	1.515 (38.48) max.
3 pole	2.265 (57.53) max.
4 pole	3.015 (76.58) max.

Note: Tolerance ± .015 [.38] unless noted.
Dimensions in brackets [] are millimeters.

Series Trip

The most popular configuration for magnetic protectors is the series trip where the sensing coil and contacts are in series with the load being protected. The handle position conveniently indicates circuit status. In addition to providing conventional overcurrent protection, it's simultaneously used as an on-off switch.

Switch Only

In the event that over-current protection is not desired, the coil mechanism can be deleted, providing an excellent low cost, single or multi-pole power switch.

Series

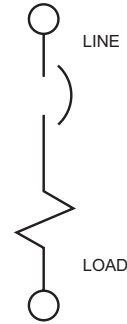

Switch Only



Three Pole Schematic Diagram

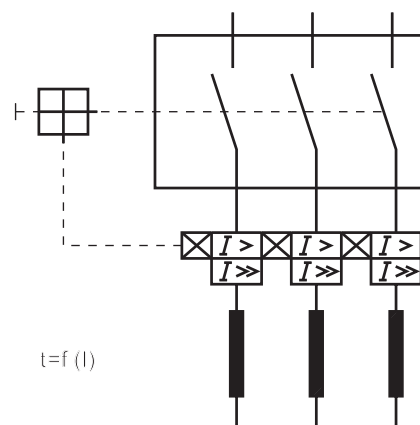

Typical Breaker Resistance/Impedance Chart

Current Ratings in Amperes	DC Delays		50/60Hz Delays		400Hz Delays	
	Resistance in Ohms		Impedance in Ohms		Impedance in Ohms	
	51, 52, 53, 59		61, 62, 63, 69		41, 42, 43, 49	
.200	45.8		28.5		71.94	
1.0	1.38		1.10		2.85	
2.0	.371		.29		.76	
5.0	.055		.051		.12	
10.0	.017		.016		.032	
20.0	.006		.006		.010	
30.0	.003		.004		.006	
50.0	.0019		.0018		.0019	
60.0	.00157		.00134			
70.0	.00147		.00133			

Notes: DCR and impedance based on 100% rated current applied and stabilized for a minimum of one hour.
 Tolerance .05-2.5 amperes ± 20%; 2.6-20 amperes ± 25%; 21-70 amperes ± 50%.
 Consult factory for special values and for coil impedance of delays not shown.

Percentage Overload vs Trip Time in Seconds for Delay Curves

Delay	100%	125% (Note A)	150%	200%	400%	600%	800%	1000%
41	No trip	May trip	.5 - 8	.15 - 1.9	.02 - 4	.006 - .25	.004 - .1	.004 - .05
42	No trip	May trip	5 - 70	2.2 - 25	.40 - 5	.012 - 2	.006 - .2	.006 - .15
43	No trip	May trip	35 - 350	12 - 120	1.5 - 20	.012 - 2.2	.01 - .22	.01 - .1
49	No trip	May trip	.100 max.	.050 max.	.020 max.	.020 max.	.020 max.	.020 max.
51	No trip	.5 - 6.5	.3 - 3	.1 - 1.2	.031 - .5	.011 - .25	.004 - .1	.004 - .08
52	No trip	2 - 60	1.8 - 30	1 - 10	.15 - 2	.04 - 1	.008 - .5	.006 - .1
53	No trip	80 - 700	40 - 400	15 - 150	2 - 20	.23 - 9	.018 - .55	.012 - .2
59	No trip	.120 max.	.100 max.	.050 max.	.022 max.	.017 max.	.017 max.	.017 max.
61	No trip	.7 - 12	.35 - 7	.130 - 3	.030 - 1	.015 - .3	.01 - .15	.008 - .1
62	No trip	10 - 120	6 - 60	2 - 20	.2 - 3	.02 - 2	.015 - .8	.01 - .25
63	No trip	50 - 700	30 - 400	10 - 150	1.5 - 20	.4 - 10	.013 - .85	.013 - .5
69	No trip	.120 max.	.100 max.	.050 max.	.022 max.	.017 max.	.017 max.	.017 max.
71	No trip	.44 - 10	.3 - 7	.1 - 3	.03 - 1	.012 - .3	.004 - .15	.004 - .1
72	No trip	1.8 - 100	1.7 - 60	1 - 20	.15 - 3	.04 - 2	.008 - .79	.006 - .28
73	No trip	50 - 600	30 - 400	10 - 150	1.8 - 20	.22 - 10	.18 - .88	.011 - .5
79	No trip	.120 max.	.100 max.	.050 max.	.023 max.	.016 max.	.015 max.	.015 max.

Notes: All trip times and trip currents are specified with the breaker mounted in the normal vertical position at ambient temperature of 25 C.
 Breakers do not carry current prior to application of overload.
A. 135% for delays 71, 72, 73 and 79.

Inrush Pulse Tolerance

Pulse tolerance is defined as a single pulse of half sine wave 50/60Hz peak current amplitude of 8 milliseconds duration that will not trip the circuit protector.

Delay	Pulse Tolerance
61, 62, 63 (.1-70 amp.)	12 times (approx.) rated current
61F, 62F, 63F (.1-25 amp.)	20 times rated current
61F, 62F, 63F (25.1-70 amp.)	18 times rated current

IELR RAIL-MOUNT DELAY CURVES

400Hz, DC, 50/60Hz Delay Curves (typ)

A choice of delays is offered for DC, 50/60Hz, 400Hz, or combined DC/50/60Hz applications. Delays 49, 59, 69 and 79 provide fast acting, instantaneous tripping and are often used to protect sensitive electronic equipment (not recommended where a known inrush exists). Delays 41, 51, 61 and 71 have a short delay for general purpose applications. Delays 42, 52, 62 and 72 are long enough for most transformers and capacitor loads. Delays 43, 53, 63 and 73 are extra long for special motor applications.

50/60Hz Delay Curves (typ)

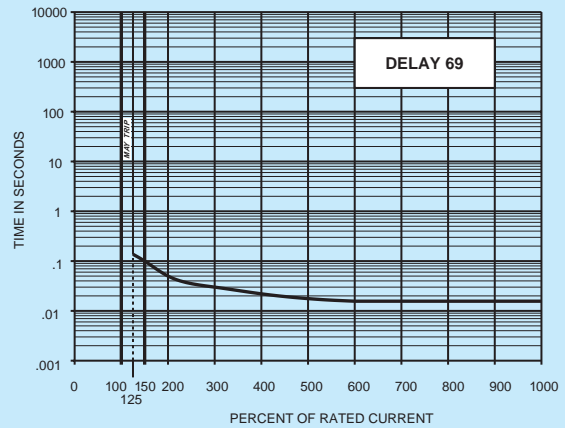
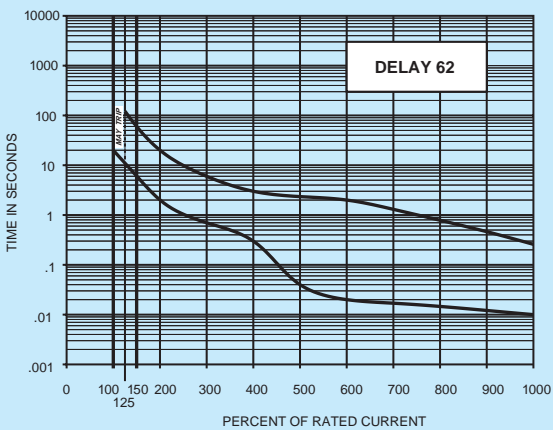
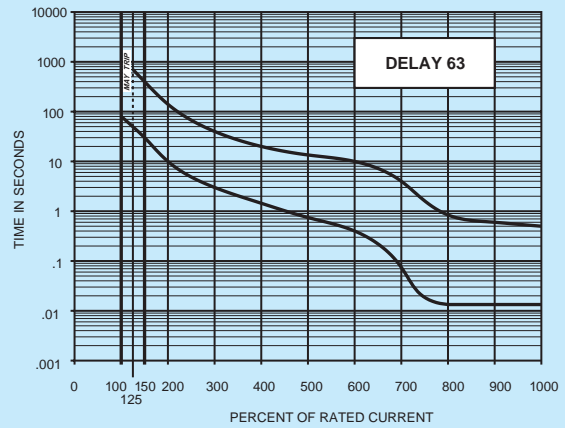
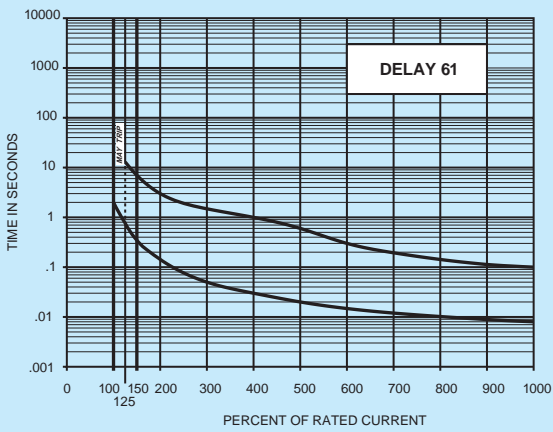

DC Delay Curves (typ)

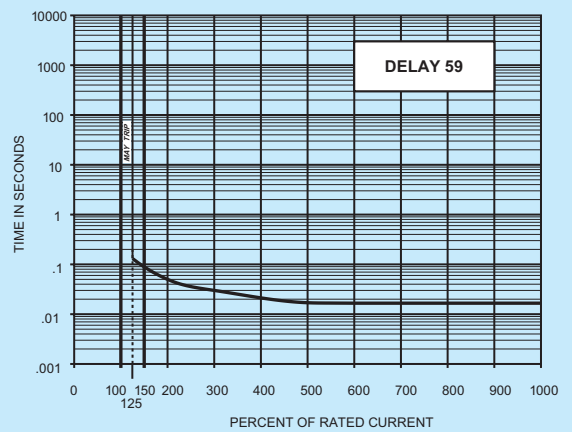
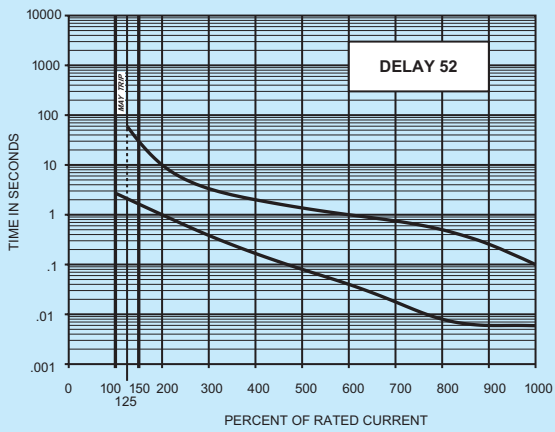
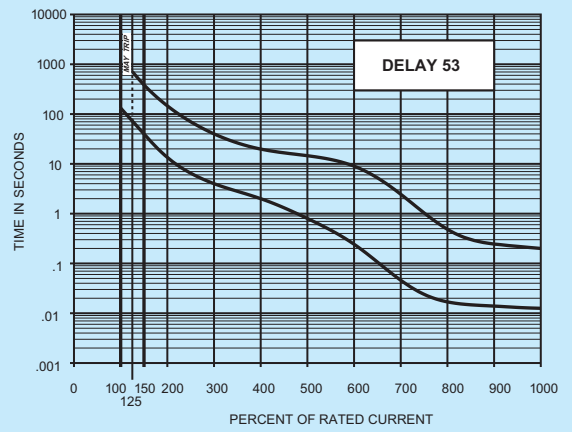
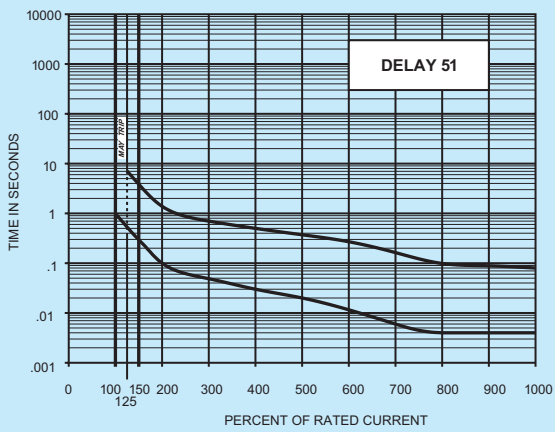

IELR RAIL-MOUNT DELAY CURVES

DC/50/60Hz Delay Curves (typ) (Multi-Frequency)

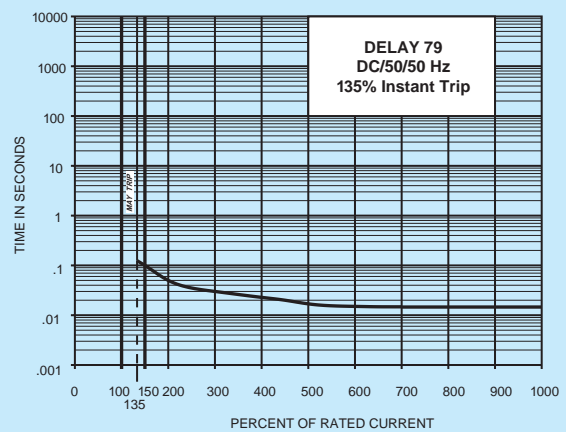
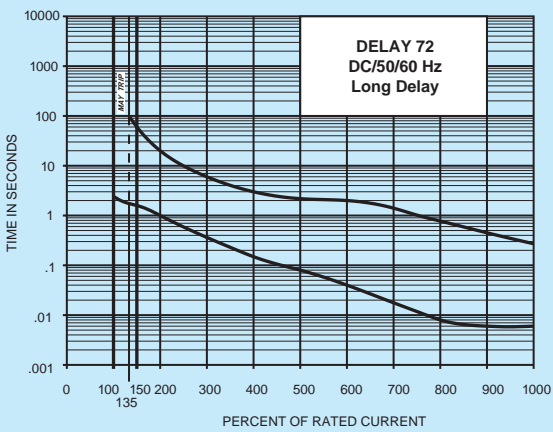
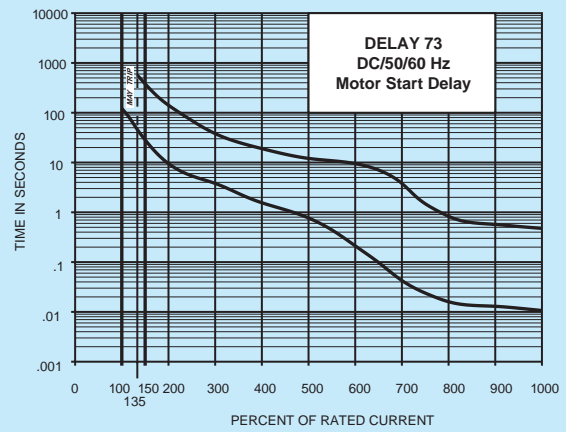
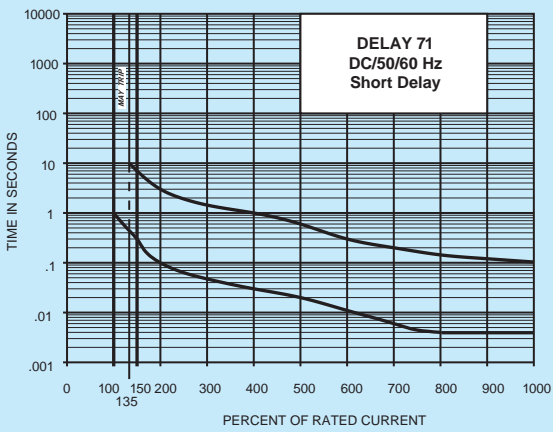

400Hz Delay Curves (typ)

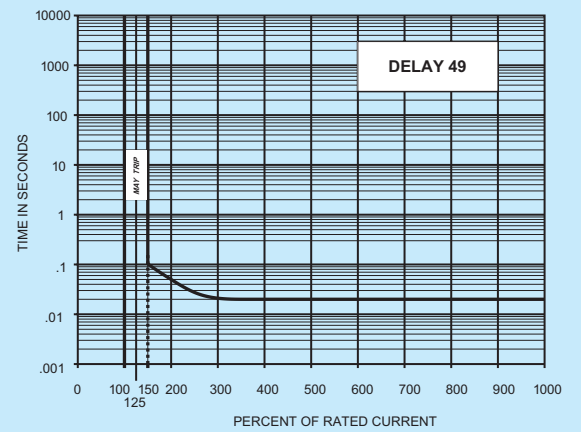
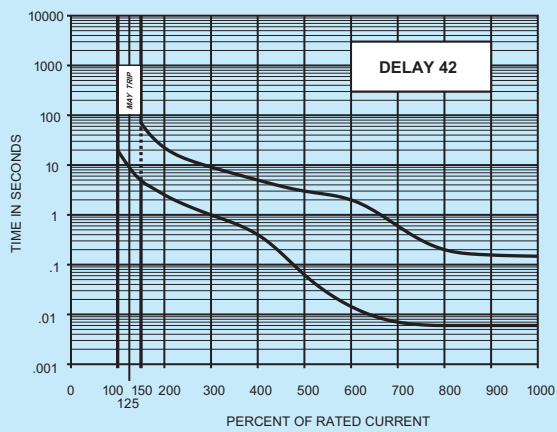
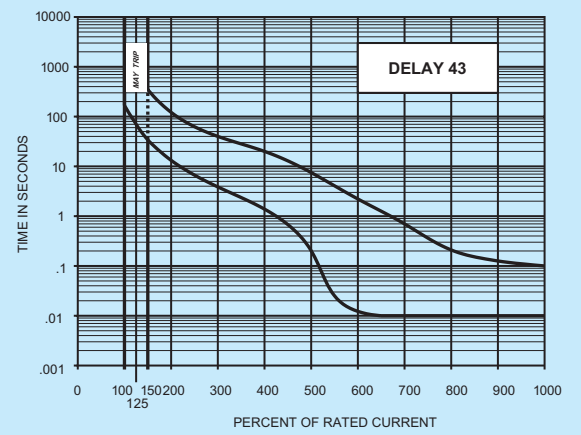
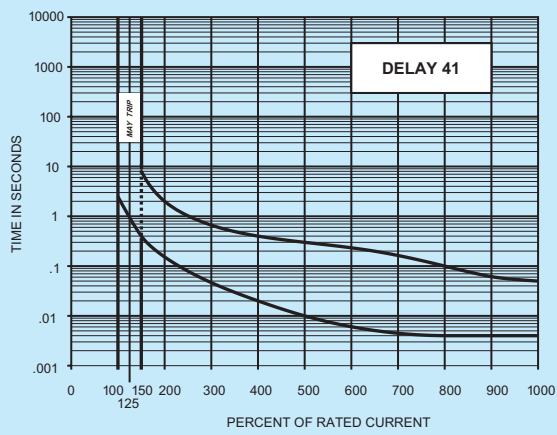

Insulation Resistance

100 megohm minimum at 500Vdc between all electrically isolated terminals.

Dielectric Strength

3750Vac (3750V~) shall withstand AC voltages 50/60Hz for 60 seconds between all electrically isolated terminals.

Endurance

Circuit protectors shall operate a minimum of 10,000 operations; 6,000 with rated current and voltage and 4,000 with no load.

Operating Temperature

-40°C to +85°C.

IEC 144 Classification

Type handle spacings - IP40. Terminals - IP00.

Moisture Resistance

10 days, 95 percent relative humidity at 40°C in accordance with IEC68-2-3, test C.

Salt Spray

Five percent solution at 35°C in accordance with IEC68-2-11, test K, 48 hours.

Shock

50g, 11m sec, half sine with rated current, except no current with handle down. Instantaneous units use 80 percent rated current. Test in accordance with IEC68-2-27, test E_g. This assumes that adequate end stops are used to prevent longitudinal movement of the circuit protector.

Vibration

4g, 5-500Hz (maximum double amplitude displacement 1.5mm) with rated current except no current with handle down. Instantaneous units use 80 percent rated current, in accordance with IEC68-2-6, test F, method A, one hour per plane. This assumes that adequate end stops will be used to prevent longitudinal movement of the circuit protector.

Agency Approvals

Voltage (V)				Rated Current (A) Minimum/Maximum		Interrupting Capacity (A)	
IAL/IUL/IEL							
Maximum Rating (V)	Frequency (Hz)	Phase	Minimum Poles	UL/CSA	VDE	UL1077 & CSA	VDE
80	DC	-	1	.05 - 50	.10 - 50	7500	4000
80	DC	-	1	.05 - 70		7500	
80	DC	-	1	.05 - 100		10000	
250	50/60	1 & 3	1	.05 - 50	.10 - 50	3500	2000
250	50/60	1 & 3	1	.05 - 70		2000	
250	50/60	1 & 3	1	.05 - 50		5000 (1)	
250	50/60	1 & 3	1	.05 - 70		5000 (1)	
277	50/60	1	1	.05 - 50		2000	
277	50/60	1	1	.05 - 50		5000 (1)	
240/415	50/60	1 & 3	2	.05 - 50	.10 - 30	2000	2000
240/415	50/60	1 & 3	2	.05 - 50		5000 (1)	
277/480	50/60	3	2	.05 - 30		2000	
250	400	1 & 3	1	.05 - 50		1750	

Note: (1) with 125A max series fuse.

How to Order

The ordering code for IELR circuit protectors may be determined by following the steps in the decision tables shown here.

The coding given permits a self-assigning part number, but with limitations. Using the illustrated coding system, it will automatically be assumed that all poles are identical. When all poles of a multi-pole protector are not identical, please contact an Airpax sales representative or the factory for a part number. One great virtue of magnetic circuit protectors is their adaptability to complex circuits. Thus, variations from pole to pole can become the rule rather than the exception. Descriptive drawings are recommended to avoid confusion.

When specifying a protector for AC motor start or high inrush applications, it is helpful to know the peak amplitude and surge duration for proper protector selection.

The part number example on page 185 is for a single pole IELR. It is series trip, delay 61, 20 amperes and has a black handle, and is VDE approved.

Notes:

When poles are not identical, each pole is to be described and a special Airpax number will be assigned.

Thomas & Betts (T&B) Narrow Tongue Lug P/N 55116 is recommended for units rated above 50A. The T&B lug or an equivalent must be used on units rated 70A and above.

1 First Decision	
Type	
IALHR	One handle per pole (multi-pole only)
IULHR	One handle per pole (multi-pole only) UL Recognized, CSA Certified and VDE Approved ratings
IELHR	One handle per pole (multi-pole only) UL Recognized, CSA Certified and VDE Approved ratings
IALR	One handle per unit
IULR	One handle per unit UL Recognized and CSA Certified ratings
IELR	One handle per unit UL Recognized, CSA Certified and VDE Approved ratings
IMLR	Mid-trip indication, One handle per unit
IMLHR	Mid-trip indication, One handle per pole

2 Second Decision	
Poles	
1	Single pole
11	Two pole
111	Three pole
1111	Four pole

3 Third Decision	
Configuration	
-0	Switch only (Omit 4th decision)
-1	Series

V = VDE Approved	
The shaded areas denote VDE Approval options. This approval requires the addition of a V at the end of the part number. The V will be added to any part number formed entirely from shaded decisions. If non-shaded areas are selected, the unit will not be VDE approved, but other approvals still apply.	

4 Fourth Decision	
Frequency & Delay	
SW	Switch Only
-41	400Hz short delay
-42	400Hz long delay
-43	400Hz motor start
-49	400Hz 150% instant trip
-51	DC short delay
-52	DC long delay
-53	DC motor start
-59	DC 125% instant trip
-61	50/60Hz short delay
-62	50/60Hz long delay
-63	50/60Hz motor start
-69	50/60Hz 125% instant trip
-71	DC/50/60 Hz short delay
-72	DC/50/60 Hz long delay
-73	DC/50/60 Hz motor start
-79	DC/50/60 Hz 135% instant trip

For addition of inertial delay, add an "F" to any delay numeral.

Example:

IELR 1 - 1 - 61 - 20.0 - 01 - V

1
2
3
4
5
7

5 Fifth Decision	
Rated Current	
Standard ratings listed. For other ratings, please contact the factory.	
.100	10.0
.250	15.0
.500	20.0
.750	30.0
1.0	35.0
2.5	40.0
5.0	50.0
7.5	60.0
	70.0

Use three numbers to print required value between .050 amperes minimum and 70.0 amperes maximum.

6 Sixth Decision	
Optional	
	Standard hardware. No designation necessary.
-A	Metric thread mounting inserts
-C	277V (50/60Hz only)
-D	240/415V (50/60Hz only)

7 Seventh Decision	
Handle Color Selection	
Unmarked	
-00	Black
-10	Yellow
-20	Red
-30	Blue
-40	Green
-60	Orange
-90	White
Marked (Combination On-Off/I-O)	
-01	Black with white markings
-11	Yellow with black markings
-21	Red with white markings
-31	Blue with white markings
-41	Green with white markings
-61	Orange with black markings
-91 (Std.)	White with black markings

